

PRODUCTS

INTELLIGENT VACUUM

LIFTING SOLUTION



SMARTLIFT

THE SAFE CHOICE

WORK SMARTER

Having a Smartlift on your team will make you **work faster and safer**. Minimize the risk of injuries from heavy lifting and work up to twice as fast during installation.

In high-rise projects, you will experience **considerable savings** compared to using a large crane outside the building. Simply install from the inside and optimize logistics by placing the glass on each floor during initial construction.

PREFERRED BY PROFESSIONALS

Every component in a Smartlift is carefully selected to ensure maximum **precision, reliability and usability**. This allows for stepless and safe operation of any Smartlift model.

We have full control of the entire supply chain and assembly processes. Therefore, we have the knowhow, flexibility and capability to act quickly and meet customer requirements.

Buying a Smartlift gives you freedom to choose from a variety of factory-installed options. Customize your lift and then add accessories for even greater utilization.

We are experts in vacuum robot technology and we know the value of swift and precise **after-sales support and service**. When you own a Smartlift, we do our best to keep you working without interruption.

JOIN THE REVOLUTION

At Smartlift, we believe that hard work and new ideas combined can drive technology and improve the way that people work. We are committed to revolutionize the glass installation process by making the best glazing robots in the industry.

That's why Smartlift is considered **the safe choice** among professionals all over the world.





HIGHLIGHT

Joystick control: This lift can turn around its own axis using the joystick.



SL208 INDOOR

LIFTS UP TO 200 KG / 440 LBS

The SL208 Indoor is our most compact and manoeuvrable lift. Easy to control using a joystick and supported by two powerful 1,500W electric motors making the lift capable of rotating on its own axis.

This glass robot is ideal for indoor installation where space might be limited or in industrial production facilities.



TURNING RADIUS
88 CM / 34 IN



LIFTING HEIGHT
274 CM / 108 IN



Compact in size and tight turning radius

TECHNICAL SPECIFICATIONS

Lifting cap. arm in/out	200/150 kg - 440/330 lbs
Lifting height	2,740 mm / 108 in
Extension of arm	500 mm / 20 in
Tip from horizontal	54° back / 53° fwd
Side shift	-
Charging voltage	230 V / 110V
Charging time	Approx. 8 hrs
Battery (2 x 12V)	2 x 70 Ah
Running period	Up to 10 hrs
Rear-wheel drive	2 x 1,500 W DC
Brake	Electro-magnetic
Suction pads	4 x Ø200 mm / 4 x Ø10 in
Width	720 mm / 28 in
Curb weight	480 kg / 1,060 lbs

BUILD YOUR SMARTLIFT

Foam-filled tyres	NA
Electric key switch	■
White, non-marking tires	■
Special Color	■
Wireless remote	■
Manual extension of the arm	NA
Electrical extension of the arm	NA
Electrical rotating yoke	NA

■ Select the options you need



HIGHLIGHT

Steering handle: Most Smartlifts are equipped with an intuitive and ergonomic drive handle.

SL280 INDOOR

LIFTS UP TO 280 KG / 620 LBS

The SL280 Indoor is a compact glass robot with more lifting capacity. The unique feature of this lift is the slim frame width of only 620 mm (25 in). This is probably the slimmest indoor glazing robot in the market today and it does not compromise on precision and ease of operation.

The rear wheel drive makes it very maneuverable with a tight turning radius. The puncture proof tires provide a secure grip on most surfaces.



SIDE SHIFT
10 CM / 4 IN



LIFTING HEIGHT
270 CM / 106 IN



More lifting power in a compact design

TECHNICAL SPECIFICATIONS

Lifting cap. arm in/out	280/160 kg - 620/350 lbs
Lifting height	2,700 mm / 106 in
Extension of arm	500 mm / 20 in
Tip from horizontal	50° back / 50° fwd
Side shift	100 mm / 4 in
Charging voltage	230 V / 110V
Charging time	Approx. 8 hrs
Battery (2 x 12V)	2 x 60 Ah
Running period	Up to 10 hrs
Rear-wheel drive	700 W DC
Brake	Electro-magnetic
Suction pads	4 x Ø300 mm / 4 x Ø12 in
Width	620 mm / 25 in
Curb weight	490 kg / 1,080 lbs

BUILD YOUR SMARTLIFT

Foam-filled tyres	NA
Electric key switch	■
White, non-marking tires	■
Special Color	■
Wireless remote	■
Manual extension of the arm	NA
Electrical extension of the arm	NA
Electrical rotating yoke	NA

■ Select the options you need



HIGHLIGHT

Remote control: All electric Smartlifts have a wired remote control for adjusting the arm and yoke.



SL380 INDOOR

LIFTS UP TO 380 KG / 840 LBS

The SL380 Indoor is a powerful mid-range vacuum lifter for indoor use and it has sideways shifting up to 10 cm (4 in) for higher flexibility during installation.

The rear-wheel drive makes the lift very manoeuvrable in narrow corridors and small spaces. Puncture proof tires provide a secure grip on most surfaces.



SIDE SHIFT
10 CM / 4 IN



LIFTING HEIGHT
270 CM / 106 IN



The SL 380 Indoor combines lifting power and flexible use indoors

TECHNICAL SPECIFICATIONS

Lifting cap. arm in/out	380/210 kg - 840/460 lbs
Lifting height	2,700 mm / 106 in
Extension of arm	500 mm / 20 in
Tip from horizontal	45° back / 105° fwd
Side shift	100 mm / 4 in
Charging voltage	230 V / 110 V
Charging time	Approx. 8 hrs
Battery (2 x 12V)	2 x 60 Ah
Running period	Up to 10 hrs
Rear-wheel drive	700 W DC
Brake	Electro-magnetic
Suction pads	4 x Ø300 mm / 4 x Ø12 in
Width	650 mm / 26 in
Curb weight	520 kg / 1,150 lbs

BUILD YOUR SMARTLIFT

Foam-filled tyres	NA
Electric key switch	■
White, non-marking tires	■
Special Color	■
Wireless remote	■
Manual extension of the arm (HL)	■
Electrical extension of the arm (HLE)	NA
Electrical rotating yoke	NA

■ Select the options you need



HIGHLIGHT

Safety first: Any Smartlift has several safety features built in to prevent overload and accidents.



Models:
High Lifter (HL)
High Lifter Electric (HLE)
High Lifter Electric RT (HLE RT)

SL580 INDOOR

LIFTS UP TO 580 KG / 1,280 LBS

Do not under estimate this heavy-duty vacuum lifter. The SL580 Indoor is excellent for handling the heaviest windowpanes, fire doors and sheets of glass without compromising on precision and ease of use.

A slim body width and the rear-wheel drive make it very maneuverable inside buildings or on the factory floor. The puncture proof tires provide a secure grip on most surfaces.



SIDE SHIFT
10 CM / 4 IN



LIFTING HEIGHT
UP TO 260 CM / 102 IN



Our most powerful lift for indoor use

TECHNICAL SPECIFICATIONS

Models	SL580 Indoor	SL580 Indoor HL / HLE	SL580 Indoor HLE RT
Lifting capacity arm in/out	580 / 280 kg - 1,280 / 620 lbs	530 / 85 kg - 1,170 / 190 lbs	480 / 75 kg - 1,060 / 165 lbs
Lifting height	2,300 mm / 96 in	2,600 mm / 102 in	2,600 mm / 102 in
Extension of arm	500 mm / 20 in	700+900 mm / 63 in	700+900 mm / 63 in
Tip from horizontal	25° back / 105° fwd	25° back / 105° fwd	25° back / 105° fwd
Side shift	100 mm / 4 in	100 mm / 4 in	100 mm / 4 in
Charging voltage	230 V / 110 V	230 V / 110 V	230 V / 110 V
Charging time	Approx. 8 hrs	Approx. 8 hrs	Approx. 8 hrs
Running period	Up to 10 hrs	Up to 10 hrs	Up to 10 hrs
Rear wheel drive	1000 W DC	1000 W DC	1000 W DC
Brake	Electro-magnetic	Electro-magnetic	Electro-magnetic
Suction pads	4 x Ø400 mm / 4 x Ø16 in	4 x Ø400 mm / 4 x Ø16 in	4 x Ø400 mm / 4 x Ø16 in
Width	780 mm / 31 in	780 mm / 31 in	780 mm / 31 in
Curb weight	685 kg / 1,510 lbs	710 / 720 kg - 1,565 / 1,590	735 / 750 kg - 1,620 / 1,650 lbs

BUILD YOUR SMARTLIFT

Foam-filled tyres	NA
Electric key switch	■
White, non-marking tires	■
Special Color	■
Wireless remote	■
Manual extension of the arm	■
Electrical extension of the arm	■
Electrical rotating yoke	■

■ Select the options you need

SL208 INDOOR

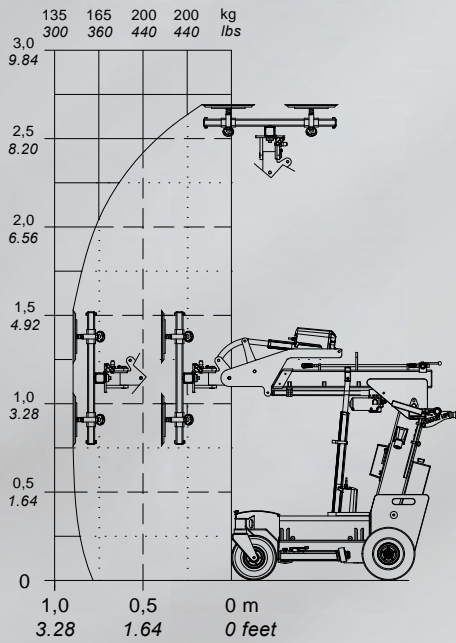

SL280 INDOOR

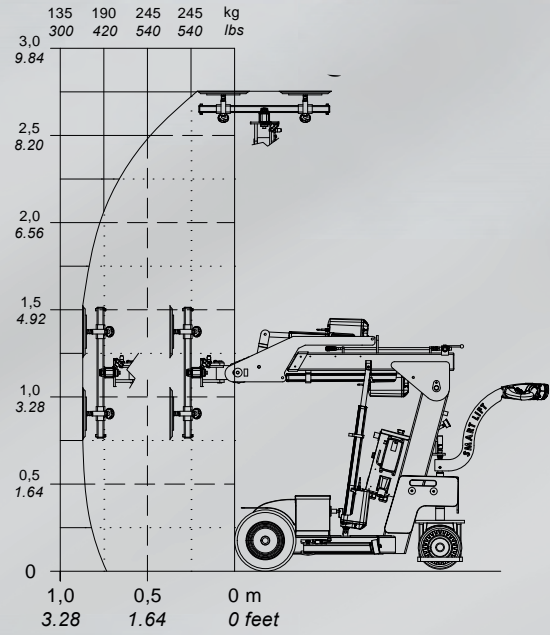

SL380 INDOOR

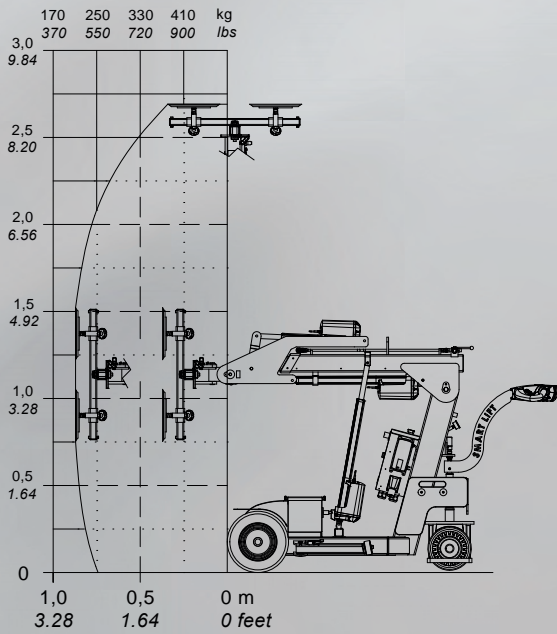

SL580 INDOOR

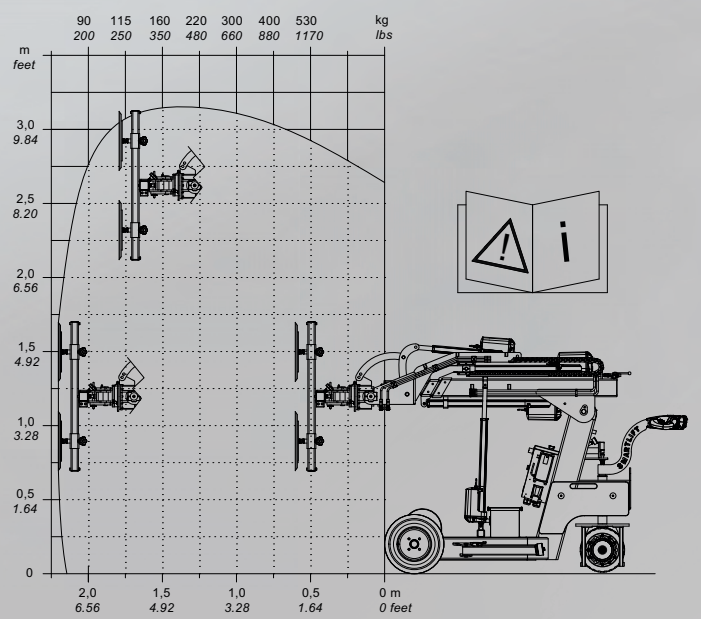



HIGHLIGHT

High Lifter option:
Choose extra manual extension of the arm for longer reach.

Models:
High Lifter (HL)
High Lifter Electric (HLE)
High Lifter Electric RT (HLE RT)

SL408 OUTDOOR

LIFTS UP TO 430 KG / 950 LBS

The SL408 Outdoor series is ideal for construction sites where versatility is key. The combination of lifting power and a compact design makes this lift relevant for glazing outdoor and indoor. Even when carrying a maximum load of 430 kg (950 lbs), the lift has more than enough power to get the job done.

The 408 series is fitted with wide twin tires to ensure that it does not get bogged down in off-road conditions. The lift is front-wheel driven and fitted with wide, puncture-proof tyres to ensure unique stability when driving with a full load. The lift is also available in a High Lifter version for additional reach.



EXTENSION OF ARM
UP TO 120 CM / 48 IN



LIFTING HEIGHT
UP TO 370 CM / 145 IN



Choose the High Lifter version for additional reach and lifting height

TECHNICAL SPECIFICATIONS

Model	SL408 Outdoor	SL408 Outdoor HL / HLE	SL408 Outdoor HLE RT
Lifting capacity arm in/out	430 / 200 kg - 950 / 440 lbs	430 / 90 kg - 950 / 200 lbs	430 / 100 kg - 430 / 90 kg 950 / 220 lbs - 950 / 900 lbs
Lifting height	3,100 mm / 122 in	3,600 mm / 142 in	3,700 mm / 145 in
Extension of arm	600 mm / 24 in	600+600 mm / 24+24 in	600+600 mm / 24+24 in
Tip horizontal	45° back/105° fwd	45° back/90° fwd	45° back/90° fwd
Side shift	100 mm / 4 in	100 mm / 4 in	100 mm / 4 in
Charging voltage	230 V/110V	230 V/110V	230 V / 110 V
Charging time	Appr. 8 hrs	Appr. 8 hrs	Approx. 8 hrs
Running period	Up to 10 hrs	Up to 10 hrs	Up to 10 hrs
Front-wheel drive	1200 W AC	1200 W AC	1200 W AC
Suction pads	4 x Ø300 mm / 4 x Ø12 in	4 x Ø 300 mm / 4 x Ø12 in	4 x Ø 300 mm / 4 x Ø12 in
Width	820 mm / 32 in	820 mm / 32 in	820 mm / 32 in
Curb weight	660 kg / 1,455 lbs	630/700 kg - 1390/1,540 lbs	Up to 730 kg / 1,600 lbs
Class	IP 65	IP 65	IP 65

BUILD YOUR SMARTLIFT

Foam-filled tyres	Standard
Electric key switch	■
White, non-marking tires	■
Special Color	■
Wireless remote	■
Manual extension (HL)	■
Electrical extension (HLE)	■
Rotation yoke RT (HLE RT)	■

■ Select the options you need



HIGHLIGHT

High Lifter option:
Choose extra manual extension of the arm for longer reach.



Models:
High Lifter Electric RT (HLE RT)

SL409 OUTDOOR

LIFTS UP TO 430 KG / 950 LBS

The new SL409 HLE RT is efficient and hard working. It saves you the cost of extra hands for mounting of elements like glass, windows, granite, marble.

The compact and ruggedized design gets the job done. You get:

- Remote controlled vacuum system
- Speedy tilting
- Save position for repeated mounting
- X/Y movement; the straight movement is easy to control and prevents damages from accidentally bumping into something
- Theft protection, geofencing and remote diagnostics with the built-in Trackunit IoT device
- New gel battery pack
- Enhanced safety features

TECHNICAL SPECIFICATIONS

Model	SL409 Outdoor HLE RT
Lifting cap. arm in/out	430 / 100 kg - 950 / 20 lbs
Lifting height	3,700 mm / 145 in
Extension of arm	600+600 mm / 24+24 in
Tip from horizontal	45° back/90° fwd
Side shift	100 mm / 4 in
Charging voltage	230 V / 110 V
Charging time	Approx. 8 hrs
Running period	Up to 10 hrs
Front-wheel drive	1500 W AC
Suction pads	4 x Ø 300 mm / 4 x Ø12 in
Width	820 mm / 32 in
Curb weight	Up to 730 kg / 1,600 lbs
Class	IP 65



EXTENSION OF ARM
UP TO 120 CM / 48 IN



LIFTING HEIGHT
UP TO 370 CM / 145 IN



Choose the High Lifter version for additional reach and lifting height

BUILD YOUR SMARTLIFT

Foam-filled tyres	Standard
Electric key switch	■
White, non-marking tyres	■
Special Color	■
Wireless remote	■
Manual extension (HL)	■
Electrical extension (HLE)	■
Rotation yoke RT (HL RT/ HLE RT)	■

■ Select the options you need



HIGHLIGHT

- 1. High Lifter option:**
Extra manual or electrical extension of the arm.
- 2. Electric rotating yoke:**
Stepless 3D movement of the arm and yoke.



Models:
High Lifter (HL)
High Lifter Electric (HLE)
High Lifter Electric RT (HLE RT)

SL608 OUTDOOR

LIFTS UP TO 600 KG / 1,325 LBS

SL608 Outdoor series offers you more power and more options. Choose longer reach and a rotating yoke for more flexibility during installation. One man can easily handle the rotation of large glass sections and experience maximum flexibility during installation.

The 608 series is fitted with twin tires to ensure that it does not get bogged down in off-road conditions. It is front-wheel driven and fitted with wide, puncture-proof tyres to ensure unique stability driving in terrain. The lift is available in a High Lifter version for additional reach and can be fitted with an electric rotating yoke.



EXTENSION OF ARM
UP TO 160 CM / 63 IN



LIFTING HEIGHT
UP TO 420 CM / 165 IN



Customize the lift to fit your exact needs by selecting from the options list below

TECHNICAL SPECIFICATIONS

Model	SL608 Outdoor	SL608 Outdoor HL / HLE / HLE RT
Lifting cap. arm in/out	600 / 280 kg - 1,325/620 lbs	600 / 150 kg - 1,325 / 330 lbs
Lifting height	3400 mm / 134 in	4,200 mm / 165 in
Extension of arm	700 mm / 27 in	700+900 mm / 27+36 in
Tip from horizontal	40° back / 100° fwd	40° back / 100° fwd
Side shift	100 mm / 4 in	100 mm / 4 in
Charging voltage	230 V / 110V	230 V / 110V
Charging time	Approx. 8 hrs	Approx. 8 hrs
Running period	Up to 8 hrs	Up to 8 hrs
Front-wheel drive	1200 W AC	1200 W AC
Suction pads	4 x Ø400 mm / 4 x Ø16 in	4 x Ø400 mm / 4 x Ø16 in
Width	830 mm / 33 in	830 mm / 33 in
Curb weight	900 kg / 1,985 lbs	Up to 960 kg / 2,120 lbs
Class	IP 65	IP 65

BUILD YOUR SMARTLIFT

Foam-filled tyres	Standard
Electric key switch	■
White, non-marking tires	■
Special Color	■
Wireless remote	■
Manual extension (High Lifter - HL)	■
Electrical extension (High Lifter Elec. - HLE)	■
Rotating yoke RT (only HL and HLE)	■

■ Select the options you need



HIGHLIGHT

- 1. High Lifter option:**
Extra manual or electrical extension of the arm.
- 2. Electric rotating yoke:**
Stepless 3D movement of the arm and yoke.



Models:
High Lifter (HL)
High Lifter Electric (HLE)
High Lifter Electric RT (HLE RT)

SL609 OUTDOOR SERIES

LIFTS UP TO 600 KG / 1,325 LBS

The SL609 HLE RT Outdoor features a long range of new and improved functionalities; designed for maximum efficiency, user-friendliness and workplace security:

- A straight up-down movement; not in a curve, but a precise and straight movement saving time and ensuring quick mounting
- Remote controlled vacuum system
- Faster operation with increased speed for lifting and tilting
- Save and reload position for repeated mounting
- Built in IoT device for theft protection, tracking & fleet management; the Trackunit data insights support better and faster technical assistance from Smartlift via remote diagnostics
- Maintenance-free gel battery pack

TECHNICAL SPECIFICATIONS

Model	SL609 Outdoor HLE RT
Lifting cap. arm in/out	600 / 150 kg - 1,325 / 330 lbs
Lifting height	4,200 mm / 165 in
Extension of arm	700+900 mm / 27+36 in
Tip from horizontal	40° back / 100° fwd
Side shift	100 mm / 4 in
Charging voltage	230 V / 110V
Charging time	Approx. 8 hrs
Running period	Up to 8 hrs
Front-wheel drive	1500 W AC
Suction pads	4 x Ø400 mm / 4 x Ø16 in
Width	830 mm / 33 in
Curb weight	Up to 960 kg / 2,120 lbs
Class	IP 65



EXTENSION OF ARM
UP TO 160 CM / 63 IN



LIFTING HEIGHT
UP TO 420 CM / 165 IN



Customize the lift to fit your exact needs by selecting from the options list below

BUILD YOUR SMARTLIFT

Foam-filled tyres	Standard
Electric key switch	■
White, non-marking tires	■
Special Color	■
Wireless remote	■
Manual extension (High Lifter - HL)	■
Electrical extension (High Lifter Elec. - HLE)	■
Rotating yoke RT (only HL and HLE)	■

■ Select the options you need

SL409 HLE RT OUTDOOR



SL1009 HLE RT OUTDOOR

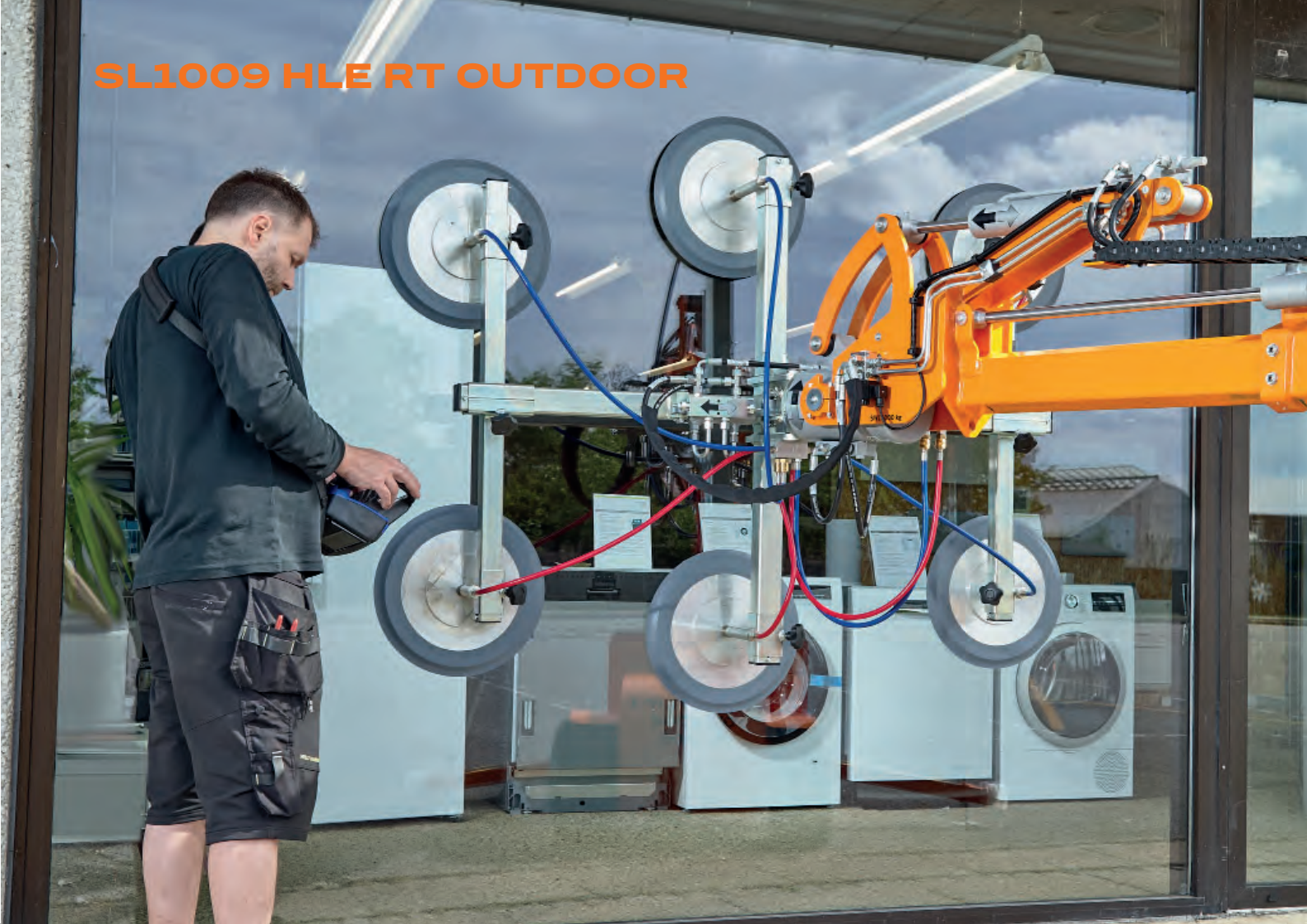



HIGHLIGHT

- 1. Rotating yoke:** Stepless 3D movement of the yoke and load.
- 2. Information display:** Monitor battery status, vacuum pressure, and load strain on the wireless remote control.

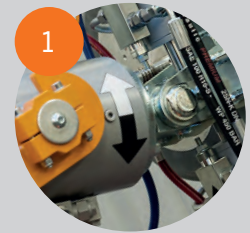

SL1009 OUTDOOR

LIFTS UP TO 1,000 KG / 2,200 LBS

The SL1009 Outdoor is our most advanced lift. It combines maximum lifting power and reach. Large window sections are easily and precisely handled using the multifunctional, rotary yoke. SL1009 has integrated IoT, and you can now locate and track your machine on an App and can follow operational hours, mandatory services checks and many more options. SL1009 is now controlled by need meaning that the entire system is using less energy.

- Some advantages of CANbus and Trackunit:
1. Vacuum release remotely controlled (Improved safety)
 2. Improved battery life time +2 hours
 3. Remote Diagnostics via Trackunit
 4. Extreme precision

TECHNICAL SPECIFICATIONS

Lifting cap. arm in/out	1,000 / 280 kg - 2,200 / 620 lbs
Lifting height	4,500 mm / 177 in
Extension of arm	2 x 830 mm / 2 x 33 in
Tip from horizontal	42° back / 86° fwd
Side shift	100 mm / 4 in
Charging voltage	230V / 110V
Charging time	Approx. 8 hrs
Battery	4 x 134 Ah AGM
Running period	Up to 8 hrs
Front-wheel drive	2500 W AC
Suction pads	6 x Ø400 mm / Ø16 in
Width	1,010 mm / 43 in
Curb weight	1,480 kg / 3,260 lbs
Class	IP 65



EXTENSION OF ARM
166 CM / 65 IN



LIFTING HEIGHT
450 CM / 177 IN



CONTROLLED BY CANBUS-FREE
TRACKUNIT INCLUDED 3 YEARS

BUILD YOUR SMARTLIFT

Foam-filled tyres	Standard
Electric key switch	■
Special Color	■
Wireless remote	Standard
Hydraulic extension of arm	Standard
Hydraulic rotating yoke	Standard

■ Select the options you need

SL408 OUTDOOR
(HIGH LIFTER)

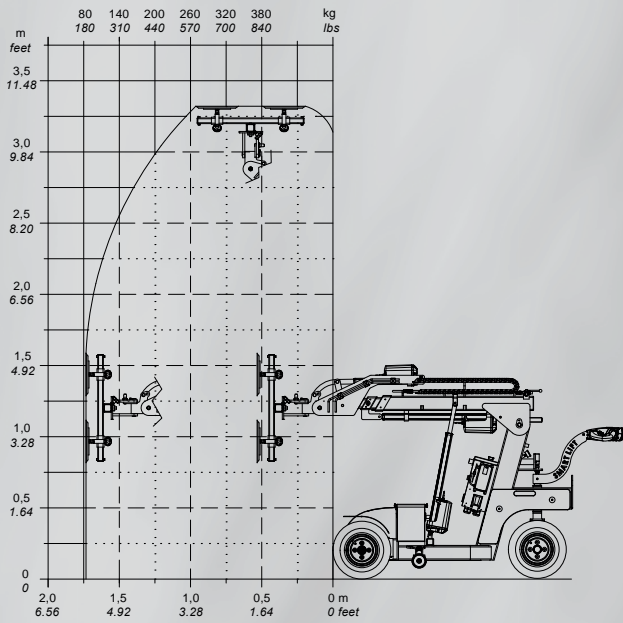

SL409 OUTDOOR
(HIGH LIFTER ELECTRIC RT)

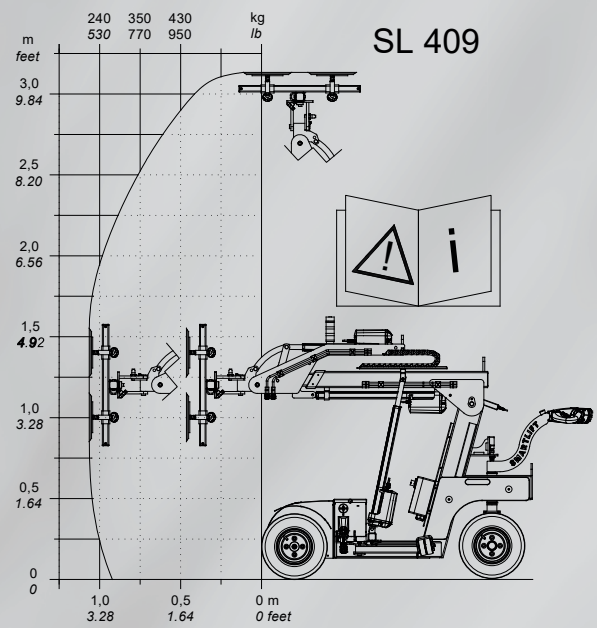

SL608 / 609 OUTDOOR
(HIGH LIFTER ELECTRIC RT)

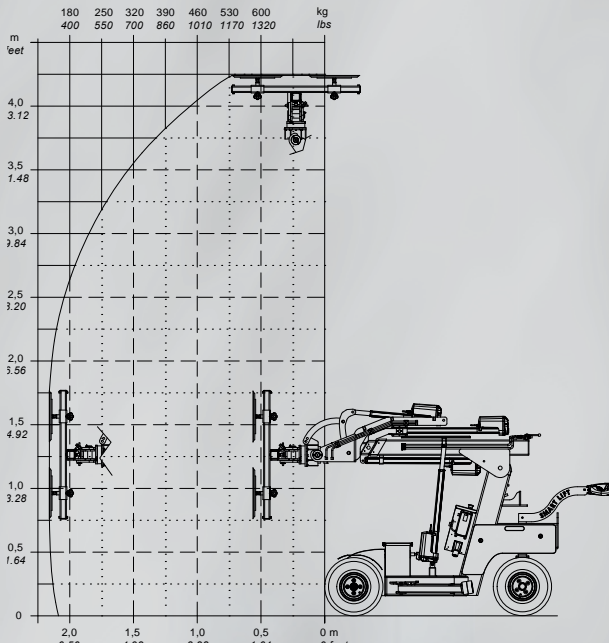

SL1009 OUTDOOR

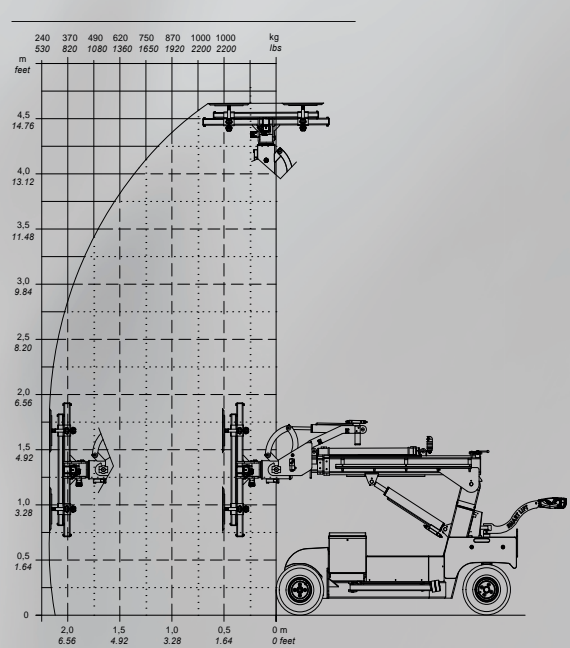



ST1300 TROLLEY

LIFTS UP TO 1,300 KG / 2,866 LBS

A rugged and self-propelled transport trolley for plasterboards and other building materials. The Smart Trolley has an electric lifter which extends up to 90 cm above ground level. Therefore it can be used as a flexible working bench at the construction site for better ergonomics. The trolley also has two side pockets for being lifted by a forklift between the floors of a building

- Self-propelled forward/reverse
- Quality bearings
- Independent wheels
- Puncture-proof tires
- Indicator for low voltage
- IP65 classified dust and moisture proof

TECHNICAL SPECIFICATIONS

WWL / rated load	1,300 kg / 2,866 lbs
Floor dimensions	1880 x 700 mm / 2,680 x 700 mm 74 x 28 in / 106 x 28 in
Floor height	600 - 900 mm / 23 - 35 in
Total length	2,850 mm / 112 in
Total length (shipped)	2,100 mm / 83 in
Wheel base	1,438 mm / 57 in
Extension - handlebar	220 mm / 9 in
Ground clearance	135 mm / 5 in
Raise / lower floor	10 sec
Driving speeds	Floor raised = 1 kmh / 0,6 mph Floor lowered = 5 kmh / 3,1 mph
Battery	2 x 12V 95Ah
Operation time	Approx. 8 hrs
Turning radius	3,1 m / 10 ft. 2 in
Charger with indicator	Integrated 110V / 230V
Curb weight	450 kg / 1000 lbs



LIFTING CAPACITY

1300 KG / 2866 LBS



LIFTING HEIGHT

90 CM / 35 IN



ST1300 Trolley comes with steering handle making it easy to operate.



SL400 SKY LIFTER RT

LIFTS UP TO 400 KG / 880 LBS

The SL400 Sky Lifter RT is a light and independent electric manipulator which can be mounted on any telescopic loader, crane etc.

Attach the SL400 Sky Lifter RT on to a telescopic loader using our quick release adaptor. This solution is ideal for buildings where installation is under overhangs or at oblique angles. The Sky Lifter can rotate 350 degrees without stop using the attached turning head. The rotation is a great advantage during the window installation, because it gives great flexibility.

The SL400 Sky Lifter RT has a wireless radio control unit. Therefore, the operator can position himself close by the window to have a detailed overview of the installation process.

TECHNICAL SPECIFICATIONS

Lifting cap. arm in/out	400 kg / 880 lbs
Lifting height	- (depends on parent)
Extension of arm	385 mm / 15 in
Tip from horizontal	- (depends on parent)
Side shift	200 + 300 mm / 8 + 12 in
Charging voltage	230 V / 110V
Charging time	No
Battery	Approx. 4 hrs
Running period	24V, 20Ah
Front-wheel drive	Up to 8 hrs
Suction pads	4 x Ø300 mm / 4 x Ø12 in
Width	360 kg / 795 lbs
Curb weight	IP 65
Class	IP 65



EXTENSION OF ARM
385 MM / 15 IN



LIFTING HEIGHT
450 CM / 177 IN



Can be fitted on a telescopic loader for maximum reach

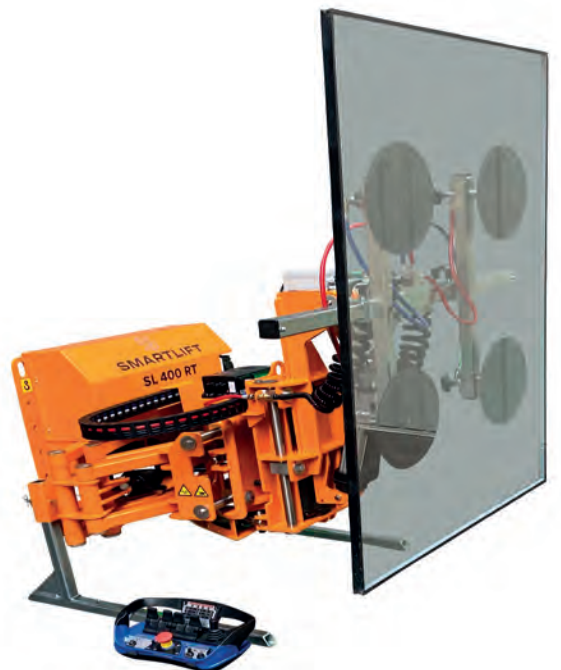

OPTIONS

■ Select the options you need

Build your Smartlift from the factory

	SL208 Indoor	SL280 Indoor	SL380 Indoor	SL580 Indoor	SL408/409 Outdoor series	SL608/609 Outdoor series	SL1009 Outdoor
Foam-filled tyres	NA	NA	NA	NA	Standard	Standard	Standard
Single Gyro	■	■	■	■	■	■	NA
Electric key switch	■	■	■	■	■	■	■
White, non-marking tires	■	■	■	■	■	■	NA
Special Color	■	■	■	■	■	■	■
Wireless remote	■	■	■	■	■	■	Standard
Manual extension of the arm	NA	NA	■	■	■	■	NA
Electrical extension of the arm	NA	NA	NA	■	■	■	Hydraulic
Electrical rotating yoke	NA	NA	NA	■	■	■	Hydraulic

SELECTED ACCESSORIES

There is a wide range of accessories available for your Smartlift. For more information, call your local dealer or go to our website.



Transport ramp

Aluminium ramps in various sizes for use indoors or outdoors.



Flexolink

Flexible connectors for curved glass. For suction pad up to Ø300mm - up to 12° curve.



Protection cover

Prolong the lifetime of the suction pads.



Suction pad bracket flex

Adjustable bracket with 200 mm adjustment for suction pads.



Lifting hooks

Strong lifting hook with a max. load capacity of up to 400, 600 or 800 kg.



Double suction pad bracket flex

Adjustable double bracket. 200 mm adjustment. For curved panes of glass.



SPK suction pads

Suitable for Paroc-and port elements with a rough surface.



Extender type

Suction pad extender. Suitable to attach loads with various levels.



Pallet fork

Various types for every Smartlift model. Max. load capacity of up to 300, 500 or 700 kg.



Cordless remote control - pocket

Available for selected Smartlift models. Replaces the cable remote control.

”

With a Smartlift, the ergonomics are fantastic. I work every day between 06:00 and 19:00, and even after a long working day I don't feel any pain in my body, because the Smartlift handles all the heavy lifts during the window installation.

– Martin Vestergaard, carpenter.



The carpentry company DN Tømrer A/S uses two SL208 Indoor Smartlifts for window installation on the ambitious urban development project Frederiksbro Stage 2. This is a completely new district in the city Hillerød with 1,300 homes and is one of the biggest housing projects in Denmark.



SMARTLIFT

CONTACT US

N.A. Christensensvej 39
7900 Nykøbing Mors
Denmark

P +45 9772 2911
E smart@smartlift.com
W www.smartlift.com