

# ELEVAH<sup>®</sup>47 picking

ELEVAH 47 PICKING

STOCK PICKERS



ELEVAH<sup>®</sup>47 compact, safe and versatile for working at heights of up to 4.60m. With its 260 kg weight and a payload capacity of 200 kg,



A large loading platform which can be adjusted automatically when raised.

Ascent and descent with maximum simplicity and safety.



Maximum thrust 8 kg



## SOME ACCESSORIES AND CUSTOMISATION



**PMES:** extralong extensible picking Platform (+20cm).

➤ OTHER ACCESSORIES AND CUSTOMISATION ON P. 46



## Technical data

<b>Max. working height</b>		4,70 m
<b>Max capacity</b>		200 kg
<b>Number of people</b>		1
<b>Use</b>		Internal - External
<b>A</b>	Closed machine height	1620 mm
<b>B</b>	Minimum platform height	395 mm
<b>C</b>	Maximum platform height	2700 mm
<b>D/E</b>	Base overall dimensions	780 x 1373 mm
<b>F/G</b>	Cage dimensions	700 x 720 mm
<b>Machine weight</b>		260 kg
<b>Dimensioni ruote fisse</b>		Ø 200 x 50
<b>Swivel wheels dimensions</b>		Ø 150 x 45



### PICKING PLATFORM

<b>Adjustment</b>		electrical
<b>H</b>	Stroke	760 mm
<b>Min. height from the ground</b>		830 mm
<b>Max. height from the ground</b>		3880 mm
<b>I/J</b>	Dimensions	477 x 786 mm
<b>Capacity</b>		80 kg

### PERFORMANCE

<b>Batteries</b>		2xAGM - 12 V 45 Ah
<b>Battery charger</b>		110V - 220V
<b>Max. speed (rising – descending)</b>		0,20 - 0,15 m/s
<b>Manual force to move it (at the start - in motion)</b>		8 - 5 kg
<b>K</b>	Maximum pressure for wheel at full load*	1,60 kN

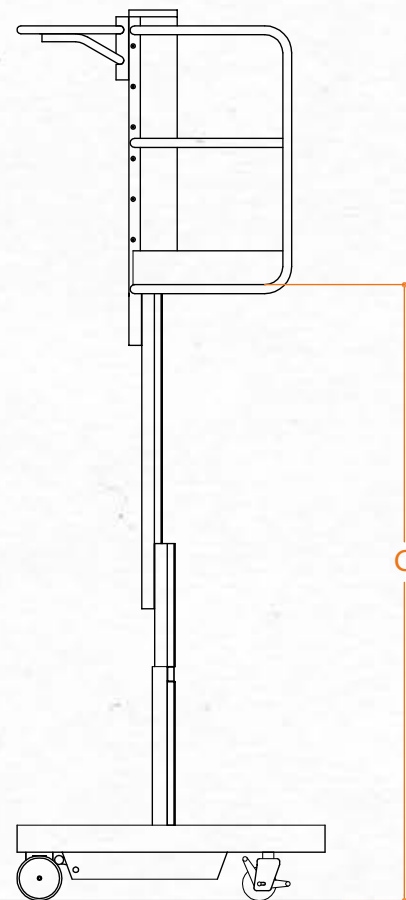
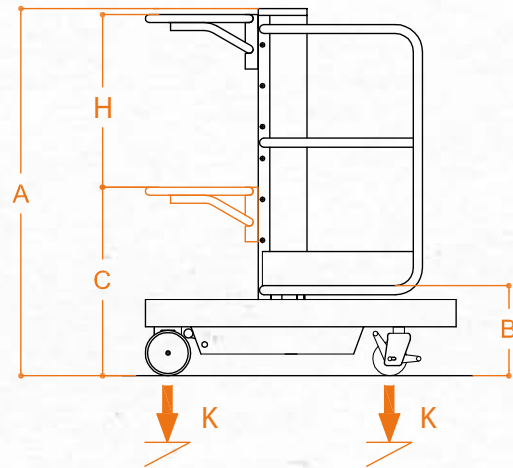

\* Maximum pressure whereas the weight of the platform plus the maximum load on the basket are completely distributed on one side of the platform (totally asymmetric load).

